

Rexnord® Belt Bucket Elevators



Steel Cord Belt Bucket Elevator

Rexnord® Belt Elevators incorporate leading edge technology

Research and development, field testing and installation experience dating back to the 1930's have allowed Rexnord to produce a belt bucket elevator that incorporates concepts and components that reflect performance technology. Rexnord® Belt Elevators are currently handling such products as cement, raw meal, alumina, coke, foundry sand, wood chips and other materials where the application parameters require a belt elevator. Rexnord elevators are currently operating with lifts in excess of 100 meters (328 feet).

Rexnord® Belt Elevator Standard Features and Benefits

- Greater conveying capacities at speeds up to 2.5 m/s (500fpm) along with "AC" style elevator buckets
- Higher lifts are possible due to the strength-to-weight ratio of the steel cord belt
- The bucket fastening method utilizes a large diameter flat head type fastener that allows the head of the fastener to be flush or slightly recessed with the surface of the belt
- Our belt material is an industry proven design that uses steel cord tension members and a cross weft construction to provide superior tracking characteristics
- Rexnord's mechanical belt splice can be installed quickly without cumbersome or dangerous use of molten metal or epoxy for cord end entrapment

- Unique metal lagging technology on head pulley provides a positive traction surface for the belt. The metal lagging offers superior wear life over replaceable rubber lagging. Also, the combination of the pulley crown and metal lagging provides continuous tracking of the belt.
- First intermediate casing above boot section has three large, double hinged access doors with quick opening latches to permit ease of installation of belt splice, buckets and routine elevator inspection.

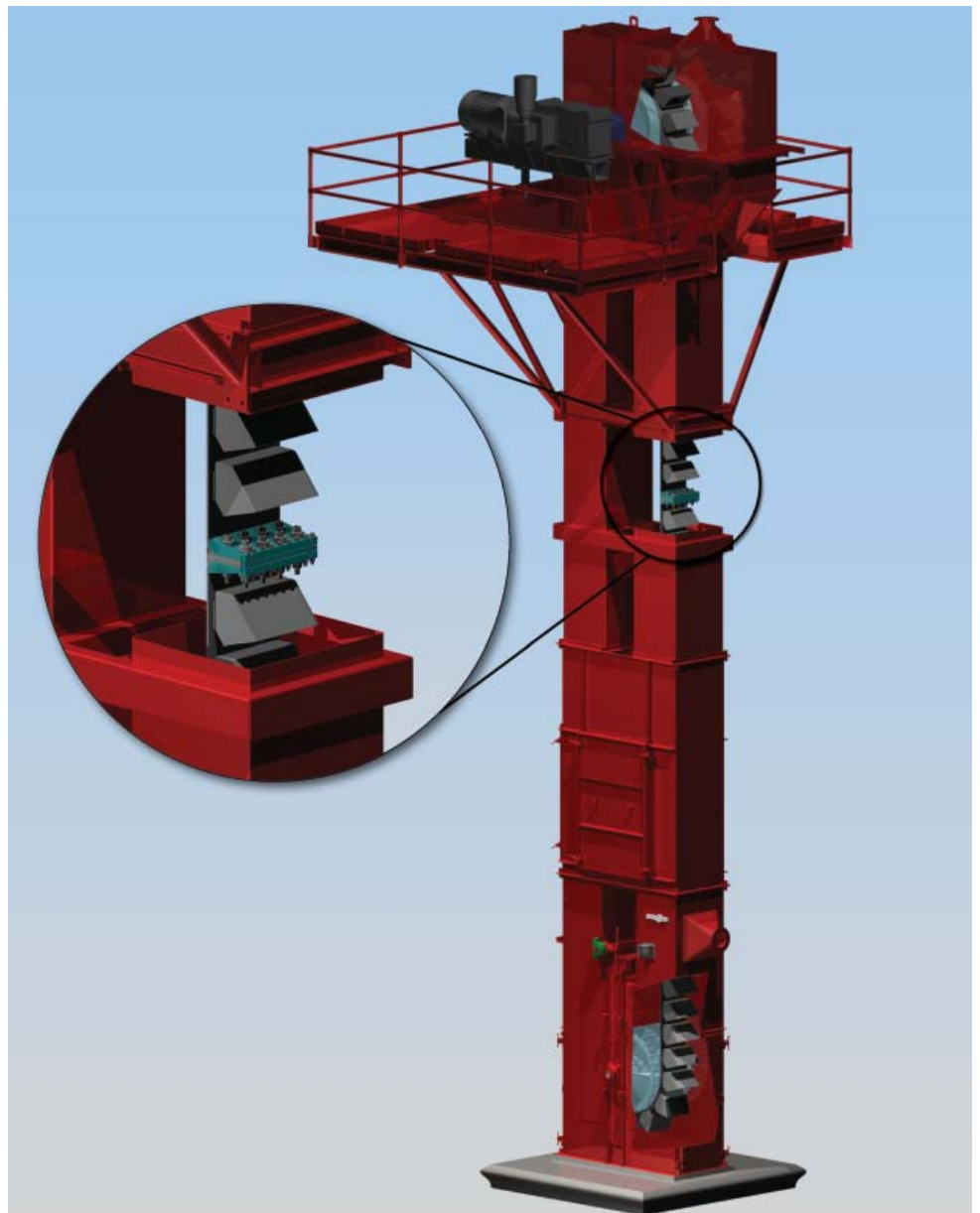

Boot Section

Rexnord counterweight external gravity take-up system provides a single point adjustment for training the belt during start-up. The take-up system is locked in after the belt is trained. To keep proper tension, the channel frame automatically adjusts as the belt stretches to allow for continuous positive tracking of the belt. Belt tracking switches alert personnel when an adjustment is required.

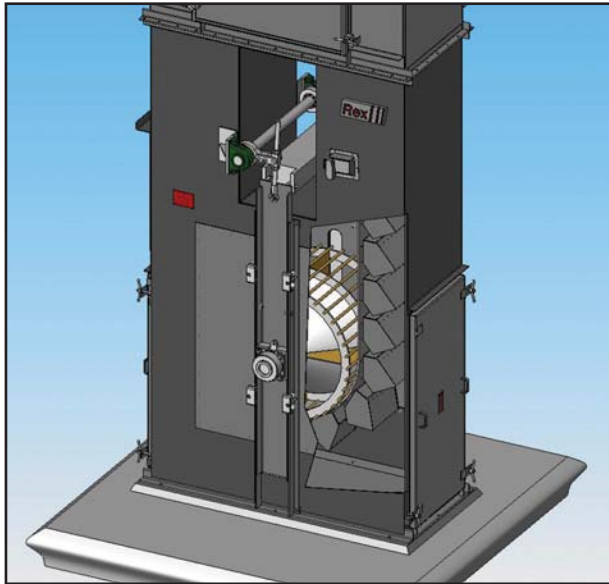

Material continuously enters the boot section through a flanged inlet opening which is properly sized and positioned to provide direct feed into buckets with reduced material spillage. If material collects in the boot section from an overfeed condition, the standard boot level sensor will warn of the situation. Quick acting latches on the removable front and rear clean out doors provide immediate access to alleviate the problem.

The foot pulley with keyless frictional shaft/hub locking devices is a wing pulley design which helps prevent material build up between the belt and pulley.

Flanged bottom provides a solid load bearing support surface on the system's foundation.

A dust collection flanged connection is also offered as an option.

Belt Splice - Steel Cord

The belt splice is one of the most critical components in the belt elevator system. The Rexnord belt splice was designed with the following key features in mind:

- strength
- resistance to fatigue
- ease of installation

The strength of the splice comes from the clamping force that is exerted on the belt ends from the two outer splice plates and the center plate. The splice fasteners use disc springs to maintain bolt tension so that the fasteners do not suffer fatigue. The disc springs are designed to compensate for the inevitable creep of the rubber belting which requires other splice designs to be re-tightened periodically. The mechanical cord clamp at the end of the splice joins the bare ends of the steel cords to provide an added safety factor to the belt splice.

A bolt tension monitoring mechanism can be added to the belt splice as an option.

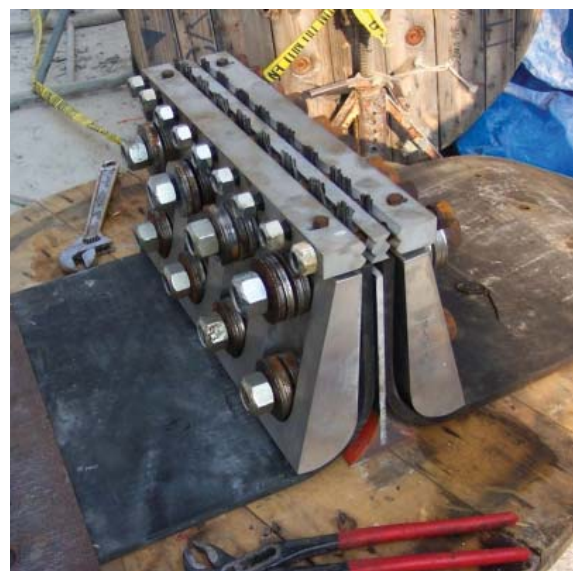

Steel Cord Belt Bucket Elevator

Head Section

The head section of the elevator is comprised of the following: head pulley assembly, gear drive assembly, discharge chute and six (6) access doors. Traction of the belt on the head pulley is optimized with a metal lagging technique to create a textured surface that provides the required friction to transmit the torque produced by the

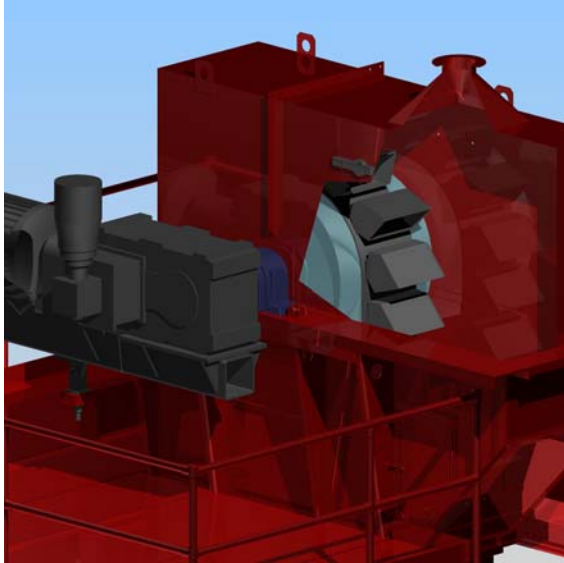

- Six (6) service doors conveniently located in lower head permit access to head shaft components and adjustable rubber lip in discharge spout which minimizes back lagging. Discharge chute can be furnished with abrasion resistant wear liners as an option.
- Head shaft bearing supports are integral with lower head section, assuring proper head shaft assembly and alignment to provide continuous tracking of the belt.
- Motion sensors in head section warn of belt slippage, missing buckets, motor coupling failure, etc.
- Four belt tracking switches permit first alarm if belt is not tracking properly.

An elevator supported service platform is offered as an option along with an optional hoist beam structure to allow service to all key components of the head section.

A dust collection flanged connection is also offered as an option.

drive assembly. Belt tracking is very sensitive to the changes in the crown shape caused by the wearing of the lagging material. Rexnord's metal lagging has been proven to provide 10 times more wear life than that of traditional rubber lagging. Rubber lagging requires annual maintenance resulting in more down time. The standard adjustable rubber peeler lip at the discharge chute picks up slow or late discharging material and helps prevent this material from collecting in the boot section. Having two (2) access doors, one (1) each side, on the discharge makes adjustment of the rubber peeler lip convenient.

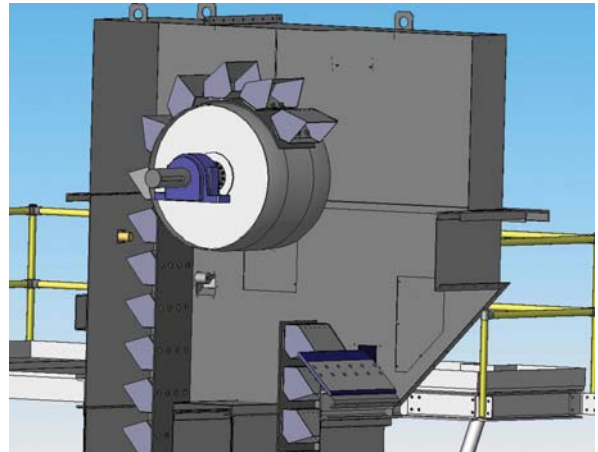

Belt Material - Steel Cord

The industry proven belt design consists of a steel cord carcass in a solid rubber mass which eliminates the concern of the belt delaminating. The steel cord belt is designed to have low elongation yet have elasticity in the length, as well as cross cords in the width. The built-in elasticity allows operation over a crowned head pulley while the cross weft construction provides continuous positive tracking of the belt. The weaving technique used in the steel cord carcass provides proper belt strength without the need of special cord free zones for bucket attachment. The belt can operate in conditions with a maximum ambient temperature up to 130°C (266°F) with short peaks of 150°C (302°F).



Steel cord bucket elevator: 63.5 m (208 ft - 3 in) centers

Buckets / Bucket Mounting

The 'AC' style buckets have a hooded back, high front and are back mounted in single or multiple rows to maximize the capacity of the belt elevator. The compact 'AC' design allows greater capacities in a smaller casing 'footprint.' Buckets are secured to the belt with large, flat-head

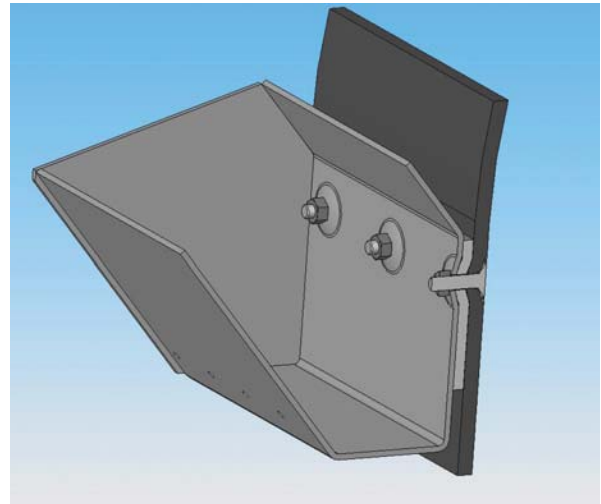

elevator bucket fasteners for positive bucket retention. The large diameter flat head type fastener along with the recessed bolt area in the bucket allows the head of the fastener to be flush or slightly recessed with the surface of the belt. The standard isolation pad between bucket and belt acts as an insulator when the material being handled has an elevated temperature. It also separates the bucket from the belt to eliminate the chance of the bucket wearing on the belt as the bucket passes over the pulleys. This provides longer service life for the elevator belt.

The bucket is vented to prevent air entrapment as well as acting as a relief when the material is discharged. This provides optimal efficiency of the elevator system.

Steel Cord Belt Bucket Elevator

Selection of Steel Cord Belt

Material Temperature	Cont. up to 60°C Max. up to 60°C Highly abrasion resistant	Cont. up to 100°C Max. up to 110°C Highly abrasion resistant	Cont. up to 130°C Max. up to 150°C Good abrasion resistant
Elevator Capacity	Capacity is dependent on bucket size: see table below for more details		
Material Size	Free-flowing fines up to 50mm (2 inch) lump size		

Specification for Steel Cord Belt Bucket Elevators

Bucket Length (mm)	Belt Width (mm)	Bucket Rows x Length	Cap. 75% Fill CFH @ 385 FPM 12 in. Spacing	Cap. 75% Fill CMH @ 1.96 m/s 305mm Spacing	Nom. Casing width (in.)	Nom. Casing width (mm)
400	450	1-400	8000	227	34	870
400	450	1-400	8700	246	34	870
400	450	1-400	9400	266	34	870
500	550	1-500	10400	294	34	870
500	550	1-500	11300	320	34	870
500	550	1-500	12200	345	34	870
600	650	1-600	13600	385	40	1020
600	650	1-600	14700	416	40	1020
700	750	1-700	15900	450	40	1020
700	750	1-700	17200	487	40	1020
800	850	1-800	19600	555	50	1270
1000	1100	2-500	22700	643	60	1530
1000	1100	2-500	24500	694	60	1530
1200	1300	2-600	27300	773	60	1530
1200	1300	2-600	29500	835	60	1530
1400	1500	2-700	31800	900	70	1780
1400	1500	2-700	34400	974	70	1780
1600	1700	2-800	39300	1113	80	2030
1800	1900	3-600	44200	1252	90	2290
2100	2200	3-700	51600	1461	100	2540
2400	2500	3-800	59000	1671	110	2800

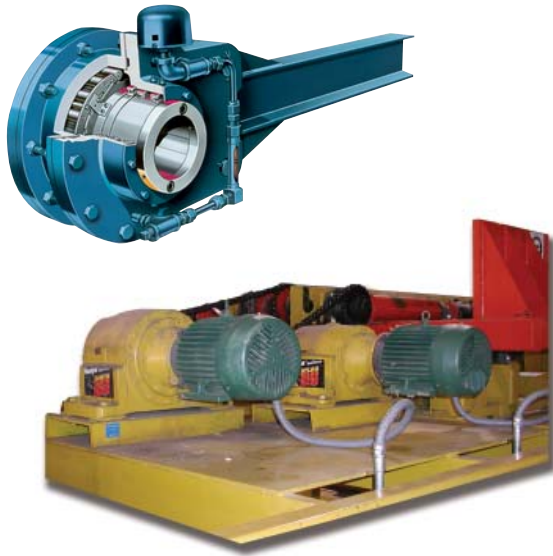

Conveying Equipment Delivers a Complete Package

The Rexnord Conveying Equipment Division designs and provides after-the-sale service on all critical components used in our equipment. This includes elevator belt, bearings, gear reducers and many others:

Gear Drives and Backstops

- Falk™ Drive One® product line
- Rexnord® Planetgear™ product line
- Falk™ Ultramax® concentric drive
- Falk™ Quadrive® shaft mounted drives
- UB Ultramite® gear motor
- Falk™ True Hold® Low Speed Backstop

Couplings

- Rexnord® Omega® Elastomer Couplings
- Falk™ Wrapflex® Elastomer Couplings
- Falk™ True Torque® Fixed-Fill Fluid Coupling
- Falk™ Orange Peel® Coupling Guards

Bearings

- Rexnord® and Link Belt® Bearings

Conveying Equipment

- Bucket elevators
- Pan conveyors
- Apron feeders
- Drag and Flight conveyors
- Rexnord® Belt Conveyor Idlers

Retrofits and Service

Capacity increases and equipment upgrades are often possible by retrofitting existing bulk material conveying equipment. We'll keep you informed of new products and existing product improvements, recommend maintenance schedules and routines, maintain replacement components, and provide people who can help, should problems ever develop.

Rexnord Conveying Equipment Division doesn't just supply the elevators; we work with our customers throughout the life cycle of the elevator.

World Class Customer Service

For more than 100 years, the dedicated people of Rexnord have delivered excellence in quality and service to our customers around the globe. Rexnord is a trusted name when it comes to providing skillfully engineered products that improve productivity and efficiency for industrial applications worldwide. We are committed to exceeding customer expectations in every area of our business: product design, application engineering, operations, and customer service.

Because of our customer focus, we are able to thoroughly understand the needs of your business and have the resources available to work closely with you to reduce maintenance costs, eliminate redundant inventories and prevent equipment down time.

Rexnord represents the most comprehensive portfolio of power transmission and conveying components in the world with the brands you know and trust.

Rexnord, Drive One, UltraMax, Quadrive, Ultramite, Omnibox, Orange Peel, and True Torque, are registered trademarks of Rexnord Industries, LLC.

Falk and Alignment-Free, Planetgear are trademarks of Rexnord industries, LLC.

Link-Belt is a registered trademark of FMC Corporation.

WORLDWIDE CUSTOMER SERVICE

AUSTRALIA

Rexnord Australia Pty. Ltd.
Picton, New South Wales
Phone: 61-2-4677-3811
Fax: 61-2-4677-3812

BRAZIL

Rexnord Correntes Ltda.
Sao Leopolda - RS
Phone: 55-51-579-8022
Fax: 55-51-579-8029

CANADA

Rexnord Canada
Scarborough, Ontario
Phone: 1-416-297-6868
Fax: 1-416-297-6873

CHINA

Rexnord China
Shanghai, China
Phone: 86-21-62701942
Fax: 86-21-62701943

EUROPE

Rexnord NV/SA
Mechelen, Belgium
Phone: 32-15-443881
Fax: 32-15-443860

Rexnord Kette GmbH
Betzdorf, Germany
Phone: 49-2741-2841
Fax: 49-2741-284-385

LATIN AMERICA

Rexnord International, Inc.
Milwaukee, Wisconsin, U.S.A.
Phone: 1-414-643-2366
Fax: 1-414-643-3222
E-mail: international2@rexnord.com

MEXICO

Rexnord S.A. de C.V.
Queretaro, Qro.
Phone: 52-442-218-5000
Fax: 52-442-218-1090

SINGAPORE

Rexnord International, Inc.
Singapore City, Singapore
Phone: 65-6338-5622
Fax: 65-6338-5422

UNITED STATES

Customer Service
Phone: 1-866-REXNORD
(1-866-739-6673)
Fax: 1-614-675-1898
E-mail: rexnordcs(state)@rexnord.com
Example: rexnordcsohio@rexnord.com

ALL COUNTRIES NOT LISTED

Rexnord International, Inc.
Milwaukee, Wisconsin, U.S.A.
Phone: 1-414-643-2366
Fax: 1-414-643-3222
E-mail: international1@rexnord.com



Rexnord Industries, LLC Industrial Chain and Conveying Equipment, 4800 W. Mitchell Street, Milwaukee, WI 53214 www.rexnord.com
P 414-643-3000 F 414-643-2600

© 2006 Rexnord Industries, LLC.

5075 09/06 Delzer Litho Printed in USA